

Modelica Tutorial at the EuroSim Congress 2007

Introduction to Object-Oriented Modeling and Simulation with Modelica

Hands-on exercises using OpenModelica

The tutorial has the following goals

- Being easily accessible for people who do not previously have a background in modeling and simulation.
- Introducing the concepts of physical modeling, object-oriented modeling and component-based modeling and simulation.
- Demonstrating modeling examples from several application areas.
- Providing opportunity for hands-on exercises with OpenModelica open-source implementation of Modelica.

The tutorial is based on Peter Fritzson's book:

Principles of Object-Oriented Modeling and Simulation with Modelica 2.1

ISBN: 0-471-47163-1
Paperback, 940 pages
February 2004, Wiley-IEEE Press

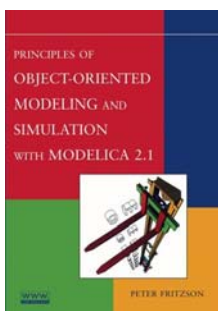

Tutorial Content

Object-Oriented modeling is a fast-growing area of modeling and simulation that provides a structured, computer-supported way of doing mathematical and equation-based modeling. Modelica is today the most promising modeling and simulation language in that it effectively unifies and generalizes previous object-oriented modeling languages and provides a sound basis for the basic concepts. The Modelica modeling language and technology is being warmly received by the world community in modeling and simulation with major applications in virtual prototyping. It is bringing about a revolution in this area, based on its ease of use, visual design of models with combination of lego-like predefined model building blocks, its ability to define model libraries with reusable components, its support for modeling and simulation of complex applications involving parts from several application domains, and many more useful facilities.

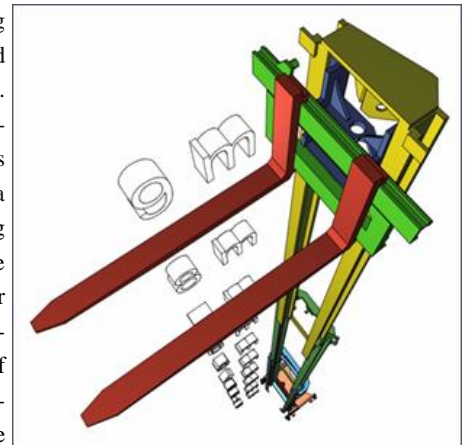

The tutorial presents an object-oriented component-based approach to computer supported mathematical modeling and simulation through the powerful Modelica language and its associated technology. Modelica can be viewed as an almost universal approach to high level computational modeling and simulation, by being able to represent a range of application areas and providing general notation as well as powerful abstractions and efficient implementations.

The tutorial gives an introduction to the Modelica language to people who are familiar with basic programming concepts. It gives a basic introduction to the concepts of modeling and simulation, as well as the basics of object-oriented component-based modeling for the novice, and an overview of modeling and simulation in a number of application areas.

Lecturer

Peter Fritzson is a Professor and Director of the Programming Environment Laboratory (Pelab), at the Department of Computer and Information Science, Linköping University, Sweden. He holds the position of Director of Research and Development of MathCore Engineering AB. Peter Fritzson is chairman of the Scandinavian Simulation Society, secretary of the European simulation organization, EuroSim; and vice chairman of the Modelica Association, an organization he helped to establish. His main area of interest is software engineering, especially design, programming and maintenance tools and environments.

Useful Links:

The OpenModelica project website:

www.ida.liu.se/~pelab/modelica/OpenModelica.html

Peter Fritzson's book:

Principles of Object-Oriented Modeling and Simulation with Modelica 2.1

<http://eu.wiley.com/WileyCDA/WileyTitle/productCd-0471471631.html>

also: www.mathcore.com/drmelica.